

Martin-Till®

Established 1991



2020

PRODUCT CATALOG

A Letter From Our Founder

Thank you for considering our products. We feel honored to be able to serve your needs. As farmers ourselves, we know the frustration that unforeseen obstacles can bring, especially inclement weather. While we can't do anything about untimely rains, we can help equip your planter to allow for more time spent planting and less time waiting to get seed in the ground.

Our customers believe that **Martin-Till®** products provide an excellent return on their investment. We know this because a large percentage of them are repeat customers. Our planter attachments help make it possible to plant into higher levels of residue and moisture. Higher levels of mulch means less erosion, improved soil tilth and fertility, which can reduce production costs. Our goal is to increase yields and save you time and money. We hope you find something in our catalog that will make this year's planting go better for you. After all, you deserve the best!

Howard Martin





Planting system.....	4-5
Hub and Bearing Assemblies.....	6
Wheels and Scrapers.....	7
Floating Row Cleaner Options and Versions.....	8-9
Floating Row Cleaners for Coulters.....	10
Parallel Link Floating Row Cleaners.....	11
Narrow Floating Row Cleaners.....	12
Floating Row Cleaners without Coulters.....	13
Unit-Mounted Fertilizer Openers.....	14
Combination Floating Row Cleaners and Fertilizer Openers.....	15-16
Rigid Mounted Pin Adjust Row Cleaners and Mounting Brackets.....	17-18
Paired 13" Spading Closing Wheels.....	19
Single 15" Spading Closing Wheels.....	20
Dimple Closing Wheels / 14" Cupped Razor Closing Wheels.....	21
Closing Wheel Options.....	22
Case IH Closing Wheels.....	23
Grain Drill Closing Wheels.....	24
Weight Transfer System.....	25
Row Cleaner Adjustment system.....	26-27
Customer Testimonials.....	28-29
How to order.....	30

Martin Till Planting System



Opening Systems

Residue clearing wheels and side treader wheels clean crop residue, dirt clods and other obstacles from the row in order to improve:

- Furrow cleaning, for improved seed-to-soil contact
- Planter row unit ride, for less bounce and twisting of unit
- Ease of disc v-opener cutting by lightly tilling the seed furrow
- Consistency of emergence by allowing soil to warm up sooner

Smart Clean™

Row Cleaner Adjustment System

The exclusive *Martin-Till® Smart Clean™* Row Cleaner Adjustment System combines a Bluetooth connection with an easy-to-use mobile app to allow the operator to raise and lower floating row units on the go by varying the amount of air pressure in the cylinders. Benefits include:

- Enhanced row unit ride
- Improved ability to properly clean the soil ahead of seed furrow to reduce residue in furrow
- Wireless control allows for less equipment in the cab
- 1 psi increments allow for more precise row cleaner control
- Eliminates dangerous, time-consuming manual row cleaner adjustments
- Ability to lift up to reduce furrowing in loose soil or push down in heavy residue at the press of a button

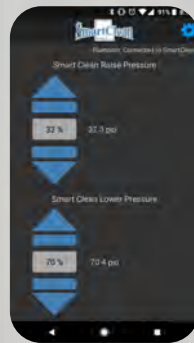

Unit-Mounted Fertilizer Openers

- Mounted rigidly to the row units, *Martin-Till®* Unit-Mounted Fertilizer Openers (UMOs) follow the row unit over undulating terrain to place crop nutrients at seed depth either one, two or three inches from the seed furrow. Features and benefits include:
- Help meet 4R's with fertilizer coulters on the planter
- Integrated design with row cleaner at front of row unit
- Low- to high-volume rate options
- Single or dual placement. Dual UMOs allow for yield-enhancing 2 X 3 x 2 fertilizer application
- Place nitrogen and fertilizer below soil surface to reduce off-site movement
- Increase nutrient use efficiency, early-season vigor and yields



Weight Transfer System

Introducing an Innovative Weight Transfer System developed by Martin Industries to assist with re-distributing weight from center of planter to wings

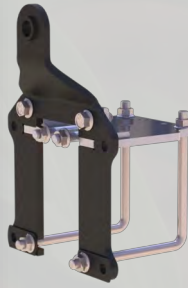

Compaction reduces plant vigor and yield. Shallow or inconsistent planting due to poor control of planter wings also robs yield. Most planters have a “weight problem”. Excess weight in

the center of the planter or improper weight distribution is a constant concern.

- In-Cab Control Box—Allows for easy adjustment as you plant
- Kits available for 12 and 16 Row JD 1770 or 1790.
- Bolt-On Bracket design (no welding) provides easy installation
- Interlocking tab and slot design fit together to transfer load to the tool bar



New Parallel Link Closing system with Second stage coming soon.



Closing Systems

Often overlooked, proper row closing is a key component of a profitable planting program.

Martin-Till® Spading Closing wheels and twisted drag chains help you seal the row for more consistent germination and emergence.

- Close the seed furrow slot without compacting the soil surface
- Reduce infiltration of light, water, air, or chemicals into seed germination zone
- Fracture sidewall compaction to improve root development
- Improve closing action in difficult cover crop situations by adding filler plates

Speed Disc™ V-Openers

Opening the seed trench is a vital part of successful planting, and *Martin-Till®* Speed Discs combine unsurpassed quality and durability to deliver these key benefits:

- The durability to stand up to heavy use with high-speed planting, contour planting, and sandy conditions
- Longer wear life for better overall value
- Heavy Duty 15” 3.5mm Boron Blade
- Fits XP style row units
- Heavy Duty double row bearing with 3 lip seal with 8 rivet hub

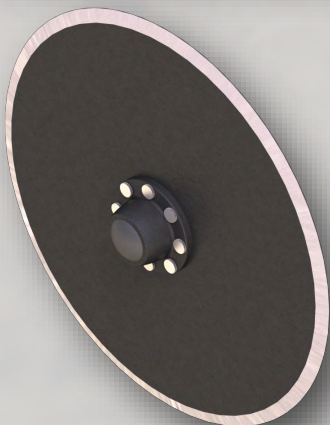

Hub & Bearing Assemblies

HA44270D Greaseable Tapered Roller Bearing with 3 lip seal

All Row Cleaners **except 1345** use our **HA44270D** hub, featuring double tapered roller bearings with a triple lip seal designed to be flushed out with grease. No need to worry about over greasing this hub we recommend greasing it annually until grease comes out to flush out contaminants. Customers often tell us they have planted with their *Martin-Till*® Row Cleaners for many, many years without needing to change the bearings. Cost savings over time and less in-field or shop labor maintenance are two important reasons farmers respect and choose *Martin-Till*® again and again.



Grease shown in yellow is injected directly between bearings

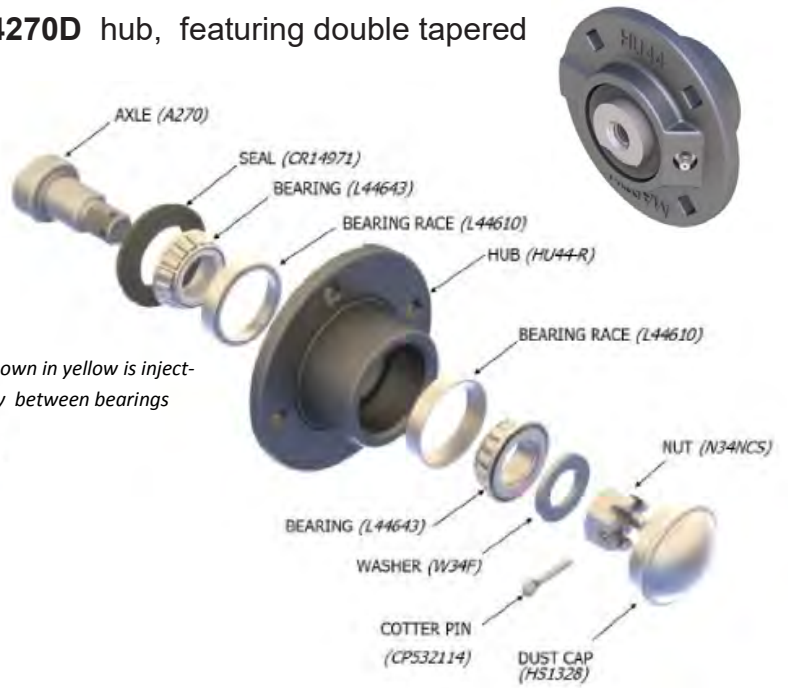

CHU44C

Double Row Ball Bearing with 6 lip seal for 1345 Row Cleaners



- Heavy duty 5205 double row ball bearing
- Maintenance free bearing features a six-lip seal design allows the life of the bearing to be increased over typical two- and three-lip designs, while removing the need for routine maintenance
- Seal design features improved contamination exclusion while maintaining standard envelope dimensions



Your choice of Spike or Razor Wheel

The 13" **Spike** wheel with 14 teeth moves the least amount of soil. The larger soil window between the teeth allows residue to be moved without moving vital soil away from the row center. The spike teeth intersect lightly till the seed zone. It comes in lefts and rights and is from 3/8" thick Boron Steel heat treated for extended long life.

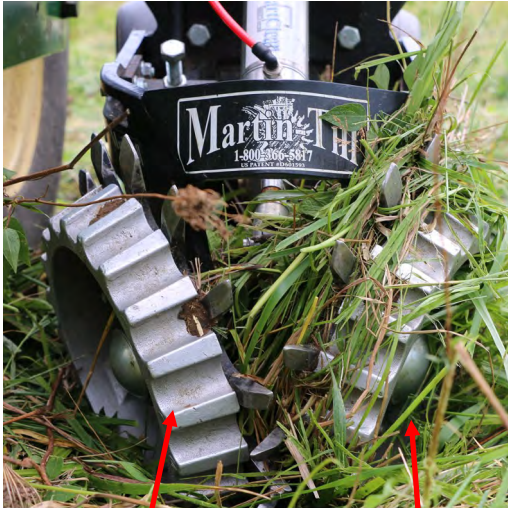

Deflector installed

No Deflector

The Spike wheel combined with provided internal deflectors (scrapers) performs well in green material.



The Internal Deflectors come standard with all row cleaners.

Add "Z" to end of part numbers to specify Razor Wheel **BD1360Z**

The 12.5" **Razor** wheel with 12 teeth performs excellently in cover crops. It will not move as much soil as competitive products but slightly more than a spike wheel. The angled teeth drop material as the wheel exits the ground preventing wrapping and when combined with our internal deflector it remains wrap free even in standing cover crops. It comes in lefts and rights with full bevel on one side vs competitive products with some bevel on both sides causing theirs to wear blunt much faster. The Razor wheel is made from 1/4" T-1 then heat treated a second time for extended long life.



- *Angled teeth exit soil pointing straight down allowing material to drop easily*

Patent Pending

Floating Row Cleaner Options



Side Treader Wheels

STW04A 3 and 4 bolt hubs
STW01K Kinze 6 bolt hub

A key component for successful planting, aluminum side treader wheels are purchased on over 95% of floating row cleaners and are designed to reduce trenching in soft soils. They also provide traction to help keep the row cleaners turning in loosely worked ground.

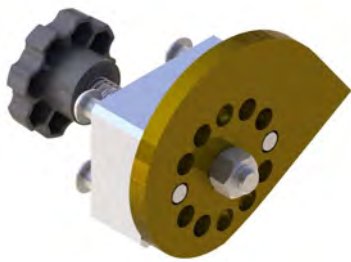

Cam Quick Adjust

CA03D 1360
CA03K 1360 for Kinze Coulter
CA45 1345

Cam adjusters are available for WA1360 and WA1345 row cleaners. They speed up the process of changing the working depth of the row cleaner frames. They are especially beneficial for growers who frequently switch from no-till to conventional tillage and do not have air cylinders.



Cylinder and Brackets

SCCYL2X2 cylinder
SC + Bundle Number for mounting brackets
(SC+BD1360) top and bottom cylinder mounting brackets

Unit Set Back Kits

USB70 Kinze
USB72 Deere

Moves the row unit back 6" to allow more clearance when installing floating row cleaners around certain no-till coulter configurations and are compatible with air bags and Precision Planting® Delta Downforce System® systems. Can be stacked for additional clearance.

Patent Pending

Floating Row Cleaner Versions



ACCR1360 Wide

ACCR1345 Narrow

ACCR1360 Wide or ACCR1345 Narrow Compact Clean Ride™ Floating Row Cleaner

- ACCR1360 Measures less than 14" from the face plate uses HA44270D Heavy Duty Greaseable Tapered Roller Bearing Hub with 3 lip seal
- ACCR1345 Measures less than 16" from the face plate uses CHU44C cast hubs and long life 5205 double row bearing with 6 lip seal
- Over 4" of vertical travel
- Allows for fitting on planters with front frame mounted nitrogen coulters or where full-size row cleaners can't be used due to planter folding/unfolding issues
- Parallel linkage allows for easy floating action, especially when paired with Martin-Till® Smart Clean™ or Precision Planting® Clean Sweep® cylinders
- Factory pre-assembled chassis saves time and makes it a cinch to install
- Choice of Spike or Razor wheel can be installed intersected or offset
- HA44270D Heavy Duty Greaseable Tapered Roller Bearing Hub with 3 lip seal

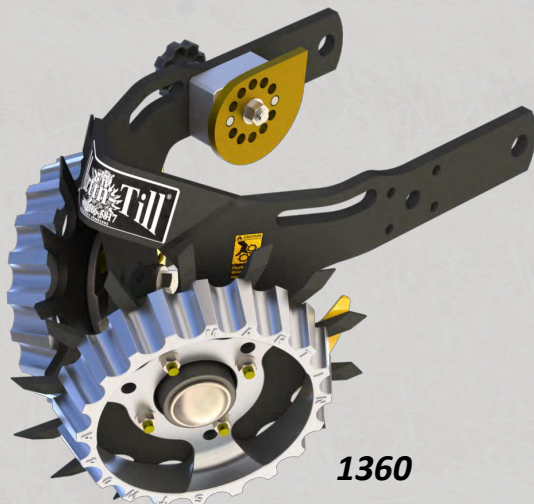

1360

Shown with optional Cam and Side Treader Wheel

1360 Floating Row Cleaner

- 60 degree heavy-duty frame
- Choice of Spike or Razor wheel can be installed intersected or offset
- HA44270D Heavy Duty Greaseable Tapered Roller Bearing Hub with 3 lip seal
- Patent No. 8,631,879, D601,593 and others pending



1345

Shown with optional Cam and Side Treader Wheel

1345 Floating Row Cleaner

- 45 degree heavy duty frame for narrow rows and high speed planting
- Choice of Spike or Razor wheel can be installed intersected or offset
- CHU44C cast hubs and long life 5205 double row bearing with 6 lip seal
- Smart Clean and Cam adjust compatible

Floating Row Cleaners For Coulters

Shown with optional,

Razor Wheels

Side Treader Wheels

Cylinder and Brackets



Basic w/o options

BDC1360

- Attaches to JD 7200 (and later) series planters with a John Deere unit mounted no-till coulter It will also install behind the John Deere single disc fertilizer opener (with extended parallel arms)
- Measures 22" from planter face plate to front of row cleaner wheels
- Choice of Spike or Razor wheel can be installed offset or intersected
- HA44270D Heavy Duty Greaseable Tapered Roller Bearing Hub with 3 lip seal
- 6" Row unit set back kits available (USB72)

BKC1360 BK4C1360

Kinze 2000, 3000
Kinze 4000



Shown with optional,

Razor Wheels

Cam Adjust

Side Treader Wheels

Cylinder and Brackets

- Attaches to Kinze planters with a unit mounted no-till coulter
- Measures 22" from planter face plate to front of row cleaner wheels 6" Row unit set back kits available (USB70)
- Choice of Spike or Razor wheel can be installed offset or intersected
- HA44270D Heavy Duty Greaseable Tapered Roller Bearing Hub with 3 lip seal

C125R The original Floating Row Cleaner

- Can be combined with most unit mounted coulters
- Choice of Spike or Razor wheel can be installed offset or intersected
- HA44270D Heavy Duty Greaseable Tapered Roller Bearing Hub with 3 lip seal
- Not recommended on JD 1700 series Contact your Martin sales rep for compatibility



Basic w/o options

ACCR1360 Wide or ACCR1345 Narrow

Compact Clean Ride (CCR) Parallel Link Row Cleaner

CCR™ improves planter performance with innovative cast parallel linkage design due to,

- Compact Design
- **ACCR1360 same stance as our BD1360** Measures less than 14" from the face plate uses HA44270D Heavy duty greaseable tapered roller bearing hub with 3 lip seal
- **ACCR1345 Perfect for high speed or narrow rows** Measures less than 16" from the face plate uses CHU44C cast hubs and maintenance free long life 5205 double row bearing with 6 lip seal
- Parallel Linkage provides over 4" travel while maintaining a consistent wheel stance when riding over uneven ground
- Compatible with Precision Planting© Conceal© as well as other frame mounted openers
- Integrated Vertical Air Cylinder brackets for Clean Sweep© or Smart Clean™ cylinders purchased separately
- Chassis is assembled at factory for easier installation onto planter row unit
- Ductile cast linkages run on heavy duty hardened oil impregnated bushings
- Choice of Spike or Razor wheels can be set up so wheels offset or intersect. Intersecting Razor wheels tear thru cover crops in seed zone



Patent Pending



1345 Narrow

1360 Standard

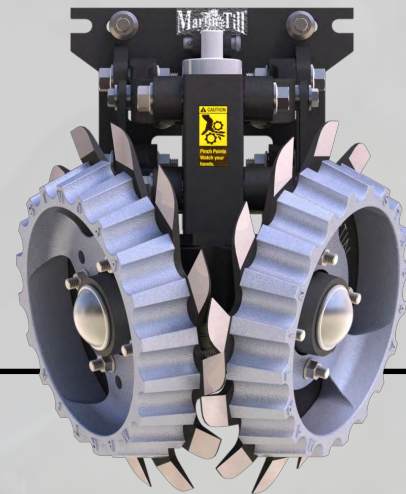

ACCR1345 Row Cleaner with Air Control

We plant both corn and soybeans on our farm. We moved to 20-inch rows recently and wanted to continue to run row cleaners. The CCR row cleaner did a great job of "peeling" the residue out of the furrow row and we didn't have any plugging issues. I like the spike wheel and how it performed. It does not move a lot of soil. The CCR with the air cylinder control has better up and down travel than competitive row cleaners and are better built. The durability is excellent. We used all season long on both crop residue types and did not have one problem. They worked phenomenally!

Mark Albers — Denton, KS

1345 Narrow Floating Row Cleaners Without Coulters

As planters get faster and row width narrower a less aggressive row cleaner is needed. Our 1345 answers this call due to:

- Narrow 45 degree frame, ideal for high speed planting or narrow rows while still clearing path for gauge wheels
- Durable CHU44C Hub with long life 6 lip double row 5205 bearing, see hub page for details
- Choice of Spike or Razor wheel can be set up so wheels offset or intersect. Intersecting Razor wheels tear thru cover crops



1345 Row Cleaner

"Moving into faster planting speeds with newer planter technology, our needs from our row cleaners changed. The Martin-Till® 1345 row cleaner gave us the ability to increase our planter speed while still managing our residue without disrupting the ride of our row units, while still maintaining the superior performance that we have come to expect from Martin Industries."

Brandon Hunt – Hunt Farms
Farmer & Tractor Pulling Professional • Hopkinsville, KY

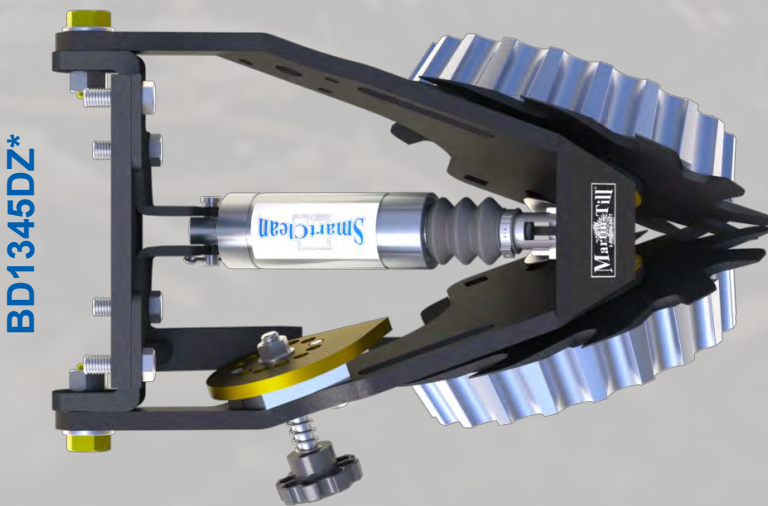

Options shown

* Shown with Razor Wheels, Side Treader Wheels, Cam adjust and air cylinder with mounting brackets

**Shown with Spike Wheels, Side Treader Wheels, Cam adjust and air cylinder and mounting brackets

BD1345

John Deere 7200 (and later) Case-IH 2000 with CNH heavy duty adapter

BKW1345

Kinze 2000 and 3000 series planters, White 6000, 8000 and 9000 series row units and Harvest International Laser Pro 1

- Measure 19" from face plate

BK41345

Kinze 4000 series

- Measures 19" from face plate

BCIH1345

Case IH 1200 series planters without frame mounted not ill coulters.

- Measures 22" from the planter unit.

1360 Floating Row Cleaners Without Coulters

BD1360 Basic

w/o options



BD1360 Deluxe

- Options added,
- Side Treader Wheels
- Cam adjust
- Smart Clean Cylinder and Brackets

BD1360**

Attach to *John Deere 7200* (and later) series planters without no-till coulters. BD1360 measures 19" from planter face plate to front of row cleaner wheels.

BKW1360***

Attach to *Kinze 2000* and *3000* series planters, *White 6000*, *8000* and *9000* series row units and *Harvest International Laser Pro 1*, without unit mounted no-till coulters. BKW1360 measures 19" from planter face plate to front of row cleaner wheels.

BK41360

Attach to *Kinze 4900* series planters without unit mounted no-till coulters. BK41360 measures 19" from face plate to front of row cleaner wheels.

BCIH1360****

Attach to *Case IH* planters without frame mounted no-till coulters. BCIH1360 measures 22" forward from the planter unit.

All row cleaners are shown with various options, including side treader wheels, cam adjuster, Smart Clean™ system and Razor Wheels.

** If equipping the rear units of a *John Deere 1790* with 1360 row cleaners, long parallel arms all the way across the rear units are strongly encouraged, especially when operating in heavy residue.

*** If installing BKW1360 row cleaners on *Kinze* Twinline planters with no-till coulters, unit set back kits will be required behind the transport wheels on the rear units. Unit set-back kits (USB70) are available from Martin-Till®. If installing BKW1360 row cleaners on *White* planters, make sure there is enough clearance between the top of the BKW1360 frame and the bottom of the planter drive shaft. Some planters may have interference problems when the row cleaners raise up on uneven ground.

**** Please note the BCIH1360 will not fit on *Case* planters that have the hexagonal drive shaft under the parallel arms. (There is not enough upward clearance above the BCIH1360 and below the parallel arms to allow the frame to float sufficiently.)

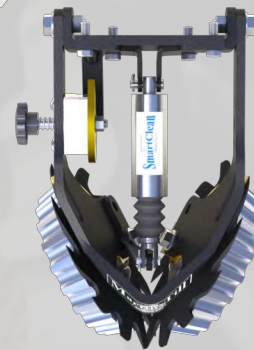

BD1360ZD

Razor Wheels in place of Spike

Deluxe with cylinder and brackets

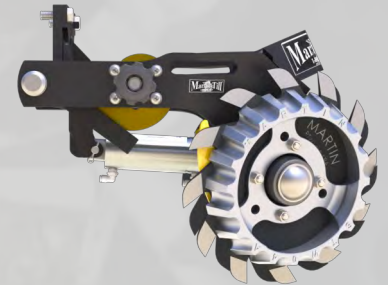

1360 Row Cleaner

On our farm we use the 1360 row cleaner on 2 *Kinze* planters. We have been using them for more than 5 years and they have required little to no maintenance. Also, our customers really like the *Martin* row cleaners. The durability and dependability of the *Martin* row cleaners allow us to recommend them with confidence. **Aaron Wolf—Farmer & Precision Ag/Equipment Sales—Wolf Farms Precision—Dixon, Illinois**

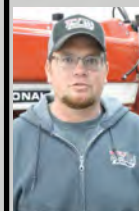

Unit-Mounted Fertilizer Openers (UMO150)

Consistently places fertilizer in the ground without splattering it on the planter!

UMO150N

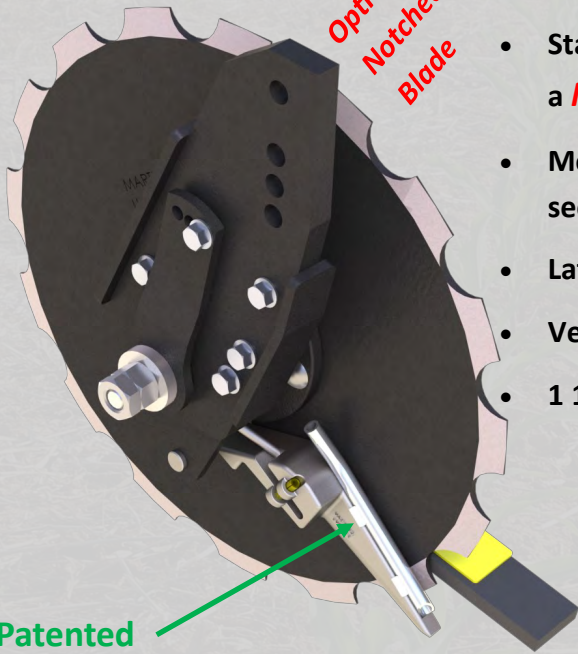

Optional 15"
Notched
Blade

- **Improved design** allows more ground clearance with a more narrow profile, reducing bulldozing.
- Standard 14" smooth blade for use in no-till conditions or a **NEW 15" notched blade** for use in min-till or conventional till .
- Mounting directly to the row unit allows precise placement from the seed, even when planting on contours
- Lateral spacing from seed can be 1" , 2" or 3"
- Vertical depth can be even with seed or 3/4" above
- 1 1/2" OD Dry tube available for 2" and 3" lateral spacing

Patented

spring loaded knife places liquid in the ground not on the planter

Furrow Control Strap keeps soil in place



UMO150

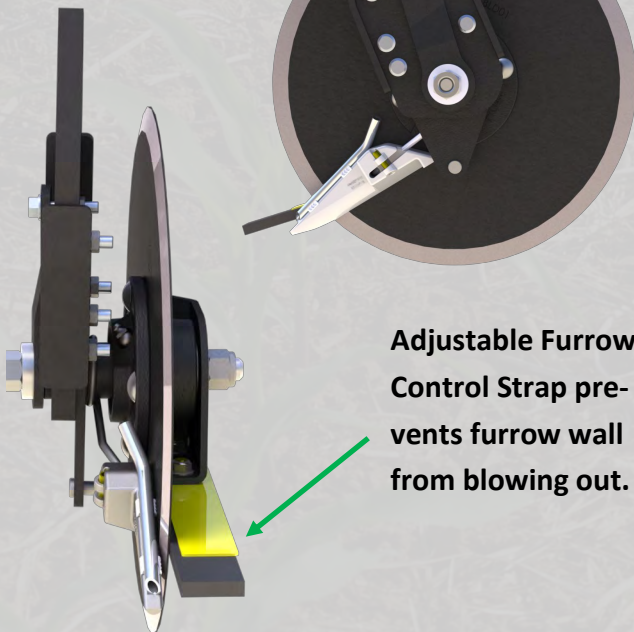

Adjustable Furrow Control Strap prevents furrow wall from blowing out.

UMO150 Features

- Sturdy compact design
- Greaseable Double tapered bearing hub with two 3 lip seals
- 5mm thick (0.197") 14" blade or 15" notched blade
- Updated & improved placement shoe for less friction
- Adjustable furrow control strap
- Can be set to place liquids 1" , 2" , or 3" from seed row
- Can also be set to place liquids 3/4" above or even with seed depth
- Fits *Deere* 7000 - 1700, *Kinze*, *White* 6000/8000/9000 series, *Harvest International Laser Pro* and *Case IH* 1200 and 2000 series planters
- Patent Number 7,481,171

Floating Row Cleaner and Fertilizer Open combos

BDUMO1345



Shown as basic without options

BDUMO1345



BDUMO1360

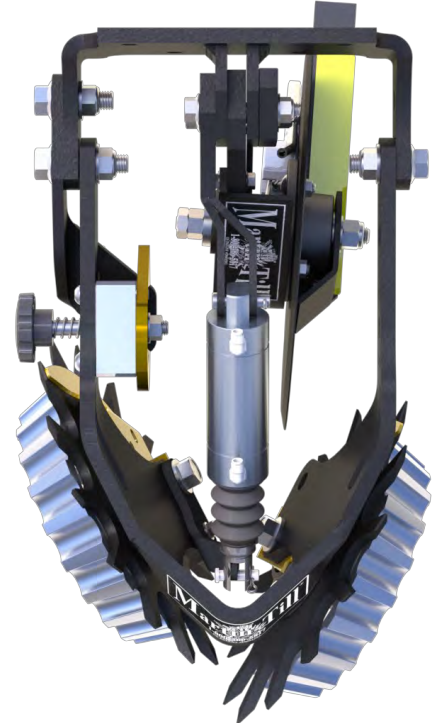

Shown with optional Cam,
Side Treader Wheels and Air Cylinder

BDUMO1360*,BDUMO1345*

1360 and 1345 floating row cleaners with **UMO150** combination. Designed to install on **7200 (and later) John Deere, White 9000** and **Harvest International Laser Pro 1**. Can be used on **Case IH 2000** with heavy duty adapter plate (**Case IH PN 4805-4385** or **Martin PN MTCNHD**). **BDUMO1360** measures 25" from face plate to front of row cleaner assembly.

BKWUMO1360, BKWUMO1345

1360 and 1345 floating row cleaners with **UMO150** combination. Designed to install on **2000 and 3000 series Kinze** planter units, **John Deere 7000**, and **White 6000 and 8000** series planters. **BKWUMO1360** measures 25" from face plate to front of row cleaner assembly.

BK4UMO1360, BK4UMO1345

1360 and 1345 floating row cleaners with **UMO150** combination. Designed to install on **Kinze 4000**. **BK4UMO1360** measures 25" from face plate to front of row cleaner assembly.

BCIHUMO1360, BCIHUMO1345

1360 and 1345 floating row cleaners with **UMO150** combination. Designed to install on **Case IH 1200 and 2000** series planter units without frame mounted no-till coulters. **Case 1200 series** requires heavy duty lower parallel arms. Will not work if drive shaft is under planter frame.

BDUMO1360



Dual UMO150

• Compatible with 1360 and 1345 row cleaners •



Features

- Dual UMOs allow for yield-enhancing 2 x 3 x 2 fertilizer application
- Your choice of Two, 14" smooth blades or 15" notched blades.
- Greaseable tapered roller bearings and 2 triple lip seals for durability
- Updated spring and placement shoe reduces friction on blade keeps blade turning in loose ground
- 3/8" O.D. delivery tube for maximum placement (up to 45 gallons per acre per opener)
- Furrow control strap reduces furrow blow-out while minimizing erosion and fertilizer spattering
- Places nutrients at various depths 3" on BOTH sides of seed for maximum usage
- Available with optional dry fertilizer tubes



Agronomic Benefits

- Allows more nutrients to be applied
- Increases root mass
- Enhances plant size and strength
- Promotes faster growth
- Improves yields

Shown with optional

- Side Treader Wheels
- Cam Adjust
- Smart Clean cylinders

Optional 1.5" OD Dry tube

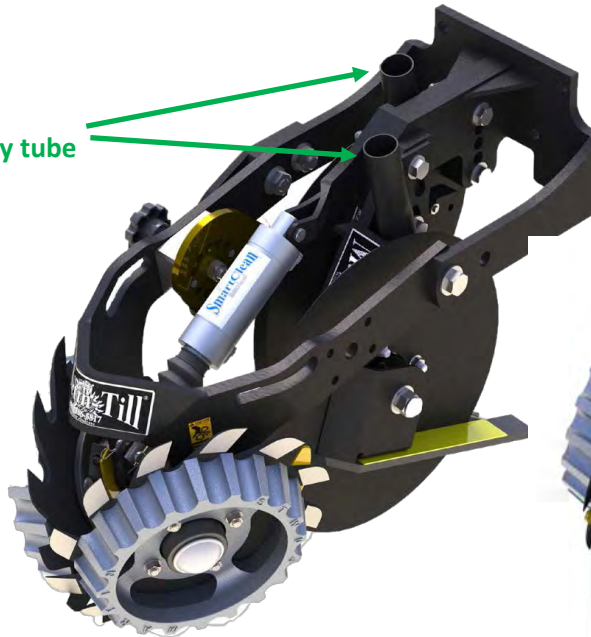
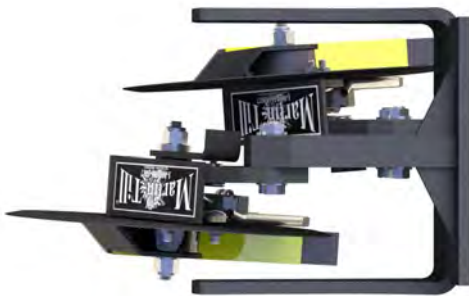

Beck's 2017 Starter Fertilizer Systems Study

TESTING LOCATIONS	STARTER PLACEMENT SYSTEM	TREATMENTS	PLACEMENT	EMERGED POPULATION	POPULATION DIFFERENCE	NEP'S %	BU./A.	BU./A. DIFFERENCE	RETURN ON INVESTMENT
IN, OH, IA	MARTIN-TILL® DUAL UMO 2x2x2	Control: 30 units UAN	2x2	32,088	-	83.6	201.4	-	-
		30 Units UAN	2x2x2	32,454	+366	82.9	207.5	+6.1	+23.55
		60 Units UAN	2x2x2	32,023	-65	83.3	211.3	+9.9	+25.01
		30 Units UAN + 1 qt Start Right	2x2	31,760	328	80.7	206.6	+5.2	+9.57
		30 Units UAN + 1 qt Start Right	2x2x2	31,773	-315	82.7	202.6	+1.2	-5.87
KY, CL, SIL	YETTER DUAL 2818 SERIES	Control: 30 units UAN	2x2	31,246	-	92.8	199.0	-	-
		30 Units UAN	2x2x2	30,407	-839	91.7	204.6	+5.6	+21.62
		60 UNITS UAN	2x2x2	30,246	-1,001	90.7	208.5	+9.5	+23.47
		30 Units UAN + 1 qt Start Right	2x2	30,458	-788	91.0	204.0	+5.0	+8.8
		30 Units UAN + 1 qt Start Right	2x2x2	30,750	-496	91.9	202.7	+3.7	+3.78

See Dual UMO Advantage

Corn \$3.86/Bu. Start Right \$42.00/gal. UAN \$.044/unit of nitrogen. Individual results may vary.

Pin Adjust Row Cleaners

Shown with MT772



Patent #5,507,351



Shown with MT892

Shown with MT772



WA1320N

Can be set offset or intersecting with your choice of wheels

Intersecting teeth reach the entire row middle and aid in cleaning one another. It's this patented cleaning action that spawned the *Martin-Till*® brand name, a name synonymous with superior performance in no-till and minimum-till planting.

Your Choice of 13" or 15" or 12.5" Razor

WA1532 or WA1332

- Rigidly mounted directly to planter unit face plate
- Easily adjustable in 1/4" increments with lift assist handle and spring
- Movable axles, via the exclusive *Martin-Till*® D-Lock System, allow for several mounting positions (intersect, offset, retracted)
- 13" toothed steel wheels with diamond shaped points allow plenty of upward adjustment in loosely worked soils
- 15" version allows teeth to extend past edge of gauge wheel works great on ridges

WA1334

- Specifically designed for *Case IH* Early-Riser planters (For use with all pin adjust brackets which accept 2" stems)

WA1320N Row Cleaners

The *Martin-Till*® Narrow Row Cleaner Model WA1320N is designed to clean residue from the vital seed trench area with less total disturbance than regular models. Two wheels are used to ensure residue is removed from the row center and not just dragged across the row, which may occur with single wheel models.

This model is recommended for 20" planters that have all units on one bar, operating in moderate residue. Because the cleaning teeth reach their maximum depth nearer the row than other models, the seed trench is more easily opened and the trench walls are more likely to crumble. The planter path will retain more moisture where this model is used than where the regular width cleaners are operated.

Pin Adjustment Brackets



MT512

Attaches to **White** 5000 Series planters. Bolts directly to planter, using existing holes. Accepts 1-1/2" wheel assembly.



MT810

Attaches to **White** 8000 Series planters. Accepts 1-1/2" wheel assembly.



MT610

Attaches to **White** 6000 Series planters with heavy duty down pressure springs. Accepts 1-1/2" wheel assembly.

MT1250

Attaches to **Case IH** 1200, 1250, 1300, and 2000 series planters for 2" tube wheel assemblies. Will not work with pneumatic down force systems.



MT892

Attaches to **Case IH** 800 and 900 series planters. For 2" tube wheel assemblies. (Additional mounting kit required for early 800 series planters).



MT772

Attaches to **Kinze, Harvest International Laser Pro, John Deere and White** 6000 & 9000 series for use with fixed row cleaner WA1332 or WA1532. Accepts 1-1/2" wheel assembly.



Dual 13" Spading Closing Wheels

BSCW1344



- For planters with bolt-on hubs: *Deere* 1700 series, *Kinze late 2000 and up* & *White 6000 & 8000*
- 3/8" thick, 13" diameter right and left toothed steel wheels with diamond shaped points
- CHU44B2 cast hubs and long life *PEER*® *SEEDX-TREME™* 40mm 5203 bearing with six-lip seal

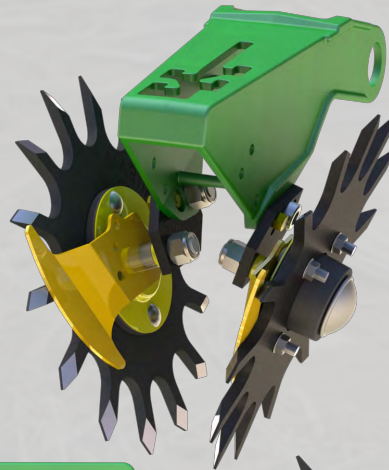

BSCW1343

- For *Deere* 7200-7300 series planters
- 3/8" thick, 13" diameter right and left toothed steel wheels with diamond shaped points
- Cast hubs
- Two 17 mm I.D. bearings

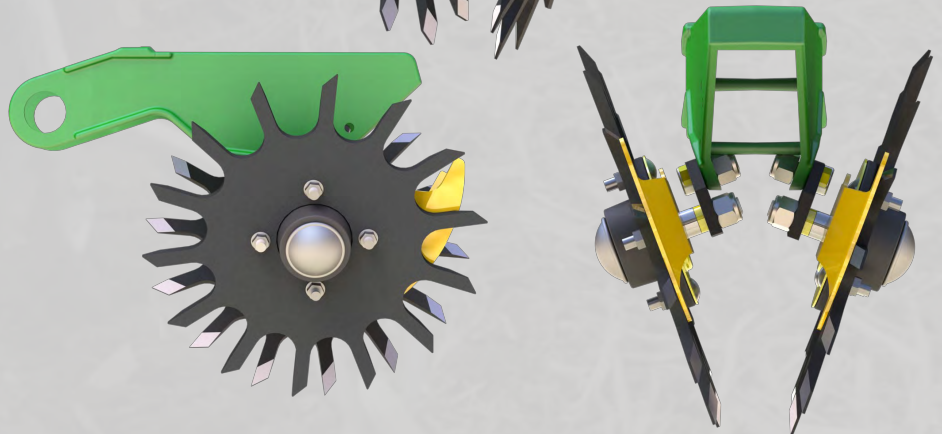

BSCW1341

- For planters with roll-pin attached hubs: *Deere 7000, Kinze early 2000*
- 3/8" thick, 13" diameter right and left toothed steel wheels with diamond shaped points
- Cast hubs
- Adapter axles
- Two 17 mm I.D. bearings

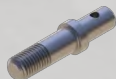

Shown with optional DK01 leveling kit for adverse conditions and Internal Deflectors

BSCW1344 pictured above on a *John Deere* 1700 series closing wheel arm with optional drop-down brackets. Drop down brackets are designed for paired 13" wheels and they help maintain a level closing wheel arm assembly in loose soils. Internal Deflector set which reduce build up of mud and residue to ensure fractured soil is placed evenly over seed trench.



Spading Closing wheels move soil toward the seed at planting depth, while lifting and fracturing the surface layer to achieve compaction free closing of the seed trench in wet, hard, or sod conditions. With soil firmed around the seed from each side and the surface layer loosened, crops emerge sooner and planting can be done at the proper depth, even in wetter conditions, without fear of crushed soil above the seed preventing emergence.



Single 15" Spading Closing Wheels



BSCW1544 L/R

- For planters with bolt-on hubs: *Deere 1700 series, Kinze, White, and Harvest International, Horsch* and others
- 3/8" thick, 15" diameter right and left toothed steel wheels with diamond shaped points
- CHU44B2 cast hubs with long life *PEER® SEEDXTREME™* 40mm 5203 double row bearing with six lip seal



* Photo Credit Southern FS, INC.

BSCW1541 L/R

- For planters with roll-pin attached hubs: *Deere 7000, Kinze early 2000*
- 3/8" thick, 15" diameter right or left toothed steel wheels with diamond shaped point
- Cast hubs
- Adapter axles
- Two 17mm I.D. bearings



BSCW1543 L/R

- For *Deere 7200* series planters.
- 3/8" thick, 15" diameter right or left toothed steel wheels with diamond shaped points
- Cast hubs
- Two 17 mm I.D. bearings



* Photo Credit Southern FS, INC.

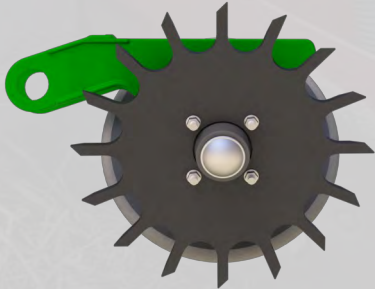
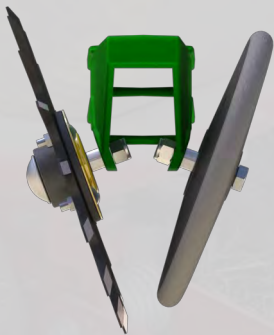
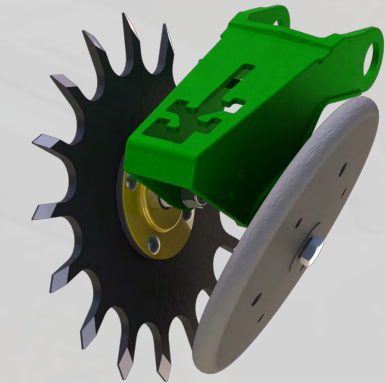

2-YEAR CLOSING WHEEL YIELD ADVANTAGE

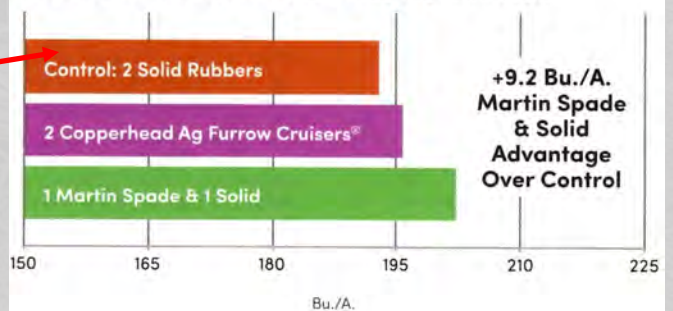

- Multi-year data at Beck's Kentucky PFR site has demonstrated one significant take home message: these soil types benefit from a crumbling, closing action, not a pressing action.
- Alternative closing wheel setups consistently outperform two solid rubber closing wheels in our research.

Dimple Closing Wheels

BSCW1344D

For planters with **bolt-on** hubs: *Deere 1700 series, Kinze 3000 and up, Harvest International, Horsch, White 6000,8000, and 9000 series and others.*

*Also available for Deere 7000, 7200 and early Kinze 2000 series planters,

- 1/2" thick, heat-treated T-1 wheels, with 20 rounded points out last poly/plastic
- Heat treated T-1 steel outlasts poly
- CHU44B2 cast hubs with long life PEER® SEEDXTREME™ 40 mm 5203 double row bearing with 6 lip seal

The BSCW1344D, 20 point dimple wheels are a sound choice for producers who plant most of their crops from medium moisture to dry conditions.

The 20 rounded points help this closing system perform well in hard sod conditions plus they frequently outperform factory closing systems in no-till and minimum till soil conditions.

BSCW1341D For planters with roll-pin attached hubs: *Deere 7000, Kinze early 2000*

BSCW1343D For *Deere 7200* series planters

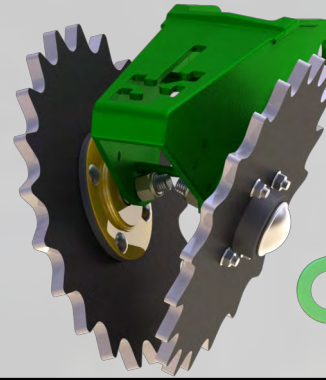

20 Rounded Points Crumble Sidewalls

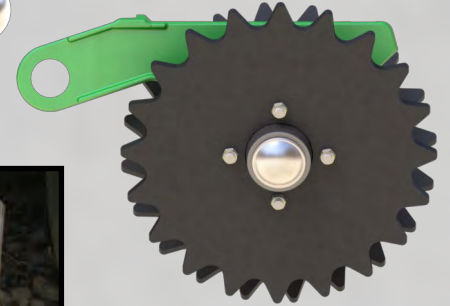

Less aggressive than spike closing wheels. Works well on high speed planters



Cupped Razor Closing Wheels

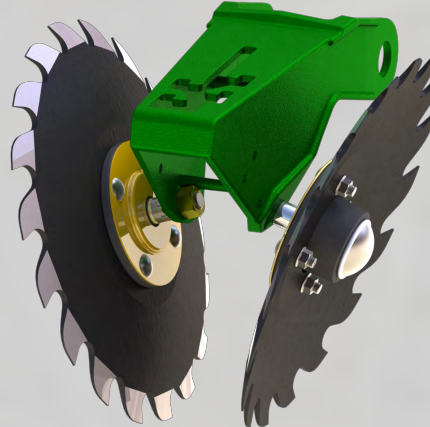

18 beveled razor style teeth Crumble Sidewalls, while cupped design squeezes trench closed.



BSCW1444C

For planters with **bolt-on** hubs: *Deere 1700 series, Kinze 3000 and up, Harvest International, Horsch, White 6000,8000, and 9000 series and others.*

- 1/4" thick, heat-treated wheels, with 18 beveled razor teeth
- CHU44B2 cast hubs with long life PEER® SEEDXTREME™ 40 mm 5203 double row bearing with 6 lip seal

The BSCW1444C, 14", 18 toothed cupped razor wheels are a sound choice for producers who plant most of their crops from high moisture to dry conditions.

BSCW1441C For planters with roll-pin attached hubs: *Deere 7000, Kinze early 2000*

BSCW1443C For *Deere 7200* series planters

Works well in cover crops



Razor Teeth break side wall while cupped design SQUEEZES soil towards seed ensuring good seed to soil contact

Options for Closing Wheels

DCK01 Drag Chain Kit

- Heavy square edge cross chain and brackets
- Bolts to all Max-Emerge units
- Fits Kinze and White units with bolt-on wheels
- Kinze 2000, JD 7000 will need holes drilled for mounting

Following behind the Closing Wheels, our Twisted Drag Chain helps to further crumble and level the soil. This helps to even out the rate of drying and ensures the soil does not dry past seed depth.

This is a low cost, low maintenance way to help increase uniform emergence in the drier parts of the field and is a must when using the spading closing wheels in minimum till. By the way, some of our customers still feel the need for some shallow tillage in the spring and the spading closing wheels and drag chain combination do an excellent job in that situation.



Depth Blade (Filler Plate)

- Proven to eliminate wrapping when planting in green or standing cover crops
- Used on both Row Cleaner and Closing systems
- Provides Depth Control and Crimping Action
- 10.5" for 12.5" Razor or 13" Spike
- 12" for 15" Spike wheel



Works well in cover crops

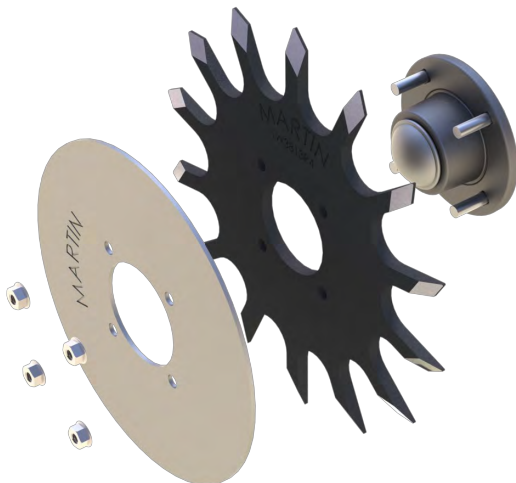

Case IH Closing Wheel

BSCW8ZC 8" Cupped Razor Closing Wheels for 800, 900 & 1200 series

BSCW95ZC 9.5" Cupped Razor Closing Wheels for 2000 series

- Replaces closing disk on Case IH planters with offset closing wheel arm
- Fits **Deere** or **Kinze** shallow closing systems

Moist soil is moved toward the seed at seeding depth. In wet conditions, the soil is prevented from forming a continuous ribbon by the lifting action of the teeth as they rotate up out of the soil.

Sharpened Teeth chips side wall while forcing soil towards seed to close furrow

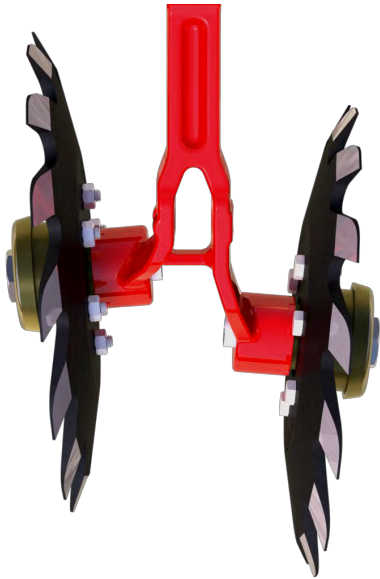

Benefits include:

- Closing wheel arm pressure can be greatly reduced
- Seeding depth does not have to be raised to ensure emergence
- Soil above the seed is loose, allowing quicker emergence in a compaction-free environment
- Sidewall compaction is eliminated

BSCW899 9" Spading Closing wheels for 800, 900 & 1200 series

9.5" Cupped Razor Closing Wheels for CASE IH

We decided to make a change on our closing wheels. We are using the Martin Razor Wheel on our row cleaners and liked the performance. Martin has introduced a new closing wheel based on similar design but made it into a cupped style wheel, so we installed it on our corn planter. In this most difficult planting season, the 9.5" Martin Cupped Razor Wheel did an excellent job. It worked better than the factory style concave version for improving closing results. It crumbled the soil very nicely to close the furrow. I was very pleased!



Wes Leeper—Leeper Farms—Marysville, OH



Grain Drill Closing Wheel

Crumbles Side walls to prevent compacting wet soil over seed

- 1/2" thick, 13" diameter with 20 rounded points crumbles side walls
- Can use 13" Spading Closing Wheels in place of 20 point Dimple in high moisture conditions

BSCW156D
for 60 and 90 series



BSCWP2D
for CNH P2000 series



BSCW75D
for 50 series



Shown with Needham Ag Firming wheel and Depth Gauge wheel

Weight Transfer System (WTS)



Can be used with frame mounted openers

- Innovative Weight Transfer System developed by Martin Industries to assist with re-distributing weight from center of planter to wings
- In-Cab Control Box—Allows for easy adjustment as you plant
- Reversible, tab interlocking, Bolt-On Bracket design (no welding) provides easy installation
- Hydraulic control kit provides durable and quick adjustment
- Bracket allows for frame mount nitrogen coulter installation
- Kits available for 12 and 16 row JD 1770 and 1790.

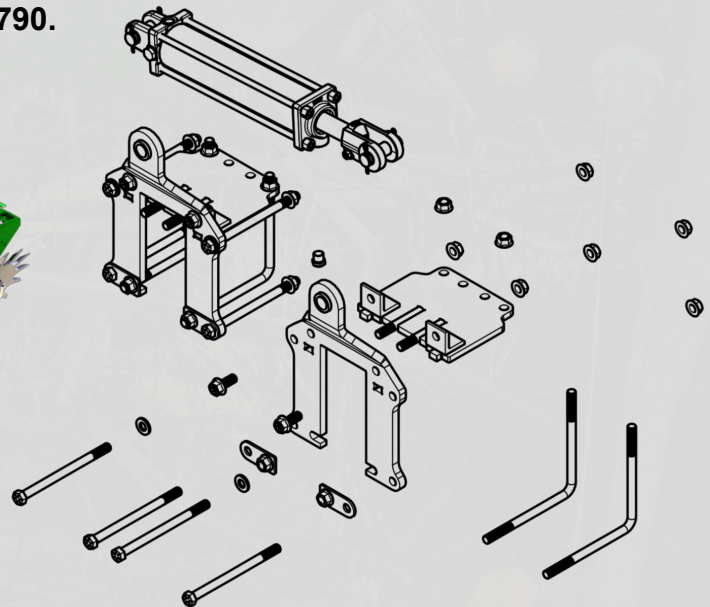
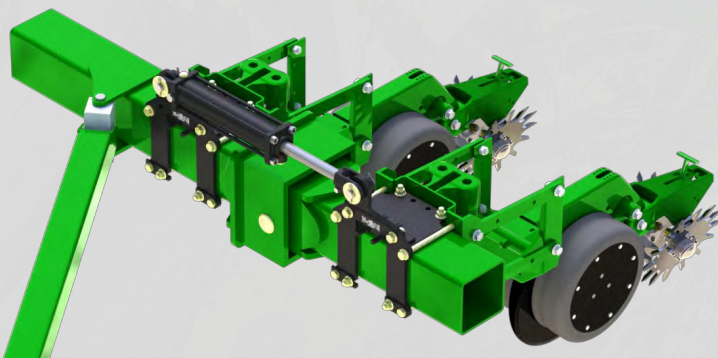

- Kit includes: Control Box, Harness, Bolt on Brackets & Bolts, Hydraulic cylinders and Hydraulic control block. *(Custom Hydraulic Hoses not included)*

Smart Clean Row Cleaner adjustment system

It's easy to add Smart Clean to any planter or strip till bar.

Simply bolt our plumbing box to the tool bar and run air lines to the compressor!

- Electronic Proportional Control valves automatically adjust to maintain desired psi
- Can be set in 1% (lbs.) increments
- App runs in background on your Smart Phone or Tablet
- Robust Bluetooth signal allows control of row cleaners while riding alongside or behind planter
- System defaults back to last settings when power is cycled or connection is lost
- No bulky boxes or air lines in cab
- Bi-Directional control option allows for pressurizing both sides of cylinder at same time (Dual Valve only)



Updated App interface coming for Spring 2020. Featuring 3 Pre Sets, Resume and Slider adjustment!



Plumbing box designed to mount on tool bar as a replacement for existing in-cab manual controls



Add **SC** to bundle number for cylinder mounting brackets (**SC+BD1360**)

SCCYL2X2 Smart Clean Cylinder



Continuous duty 200 psi fast fill

12 volt 30 amp

Smart Clean Row Cleaner Control System & Compact Clean Ride1360 Row Cleaner

For years I have been looking for a row cleaner that I could go from conventional tillage all the way through to no-till. One that is also easy to adjust from the cab, along with being dependable and durable. By installing the CCR 1360 row cleaner and Smart Clean air control system - I have now found it. It worked flawlessly from the first time in the field. I am extremely happy with the setup. It saves a lot of time, and I look forward to using it for many years. The dependability and durability of the Martin products is evident. It's the reason I sought out a system from Martin Industries. **Mike DeMean — Springville, IA**





The Smart Clean™ System makes manual row cleaner adjustments a thing of the past use your smart phone or tablet to raise lower your row cleaners.

4 ways to order Smart Clean



Single Valve with one directional control valve lets you set psi then select up down or float.

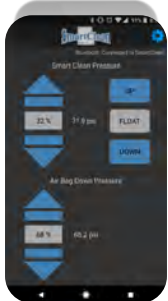

Dual valve with one directional control valve works same as single valve plus you can set psi on a second circuit to control air bags.

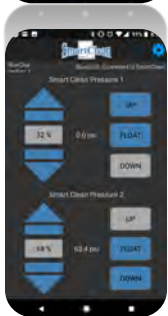

Dual valve with two directional control valves allows section control for left right or front gang back gang. Control each section independently.

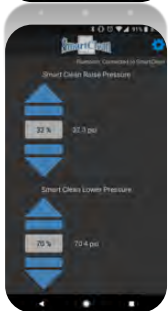

Bi-directional uses two valves allowing you to set separate air psi on both sides of piston. This method gives best control and does not come with a directional control valve.

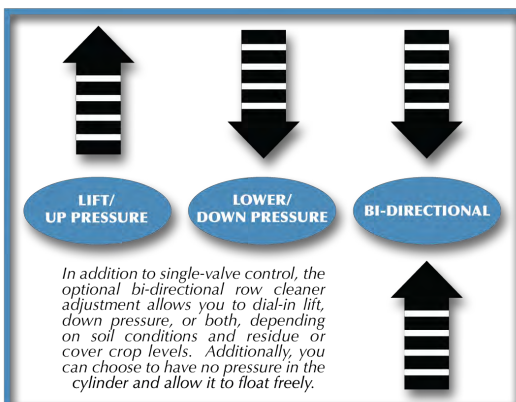

Martin-Till® Customer Testimonials



Spading Closing Wheels with Depth Blade (Cover Crops)

“One of the biggest challenges I face when planting into green living cover crops is to close the seed slot effectively. Martin-Till® has developed the Spading Closing Wheel with Depth Blade which closes the slot. I enjoy working with Martin-Till® because they see the future in cover cropping and no-till being important to the success of building soil health. That is refreshing to me. I can easily say that the Spading Closing Wheel with Depth Blade is the best closing wheel system I have used. I would recommend Martin-Till® products.”

**Rick Clark – Clark Land & Cattle
Williamsport, IN**



Compact Clean Ride™ (CCR) Row Cleaner

“The CCR is very compact and fits nicely on my planter that we have done a lot of retrofitting on. The ride is very smooth, so it reduces “plowing” concerns in our contoured strip-till rows. We have a lot of variable conditions in our fields and this is a row cleaner that I can adjust “on the go” to remove residue. We adjust the row cleaners several times per day, sometimes multiple times per field. I also like the parallel linkage design.”

Bob Bowman – Bowman Farms • Strip-Tiller • DeWitt, IA



Dimple Closing Wheels

“I have installed the Martin-Till Dimple Wheels on my 15” bean planter and drill. They have done an excellent job of closing the furrow and won’t wrap, even in heavy cover crop conditions. In the past, I have sometimes had trouble closing the furrow, especially on our drill setup. This closing system just gently “zips up the furrow” without packing the sidewall. I even find it difficult to tell where we have planted. I would recommend this setup to other farmers looking to improve their furrow closing results.”

Jerry Seidel • Belle Rive, IL



Martin Row Cleaners

On our farm, we have run Martin row cleaners on our planter for 3 years now. We had started with a competitor’s product but had performance issues so we decided to switch to Martin-Till. The Martin row cleaner has much better workmanship and quality for durability and dependable use. The competitor row cleaner had plugging concerns. When we switched to Martin row cleaners, we found no plugging and no problems at this time. We have done zero maintenance. We highly recommend Martin row cleaners to other farmers for satisfactory results.

Marshall Jokisch—Jokisch Farms



Smart Clean™ and Row Cleaners

“The Smart Clean™ row cleaner air control adjustment system from Martin-Till® worked very well on our planter this year. I have a used planter and did a lot of upgrades to improve performance. I was interested in row cleaner control for my floating row cleaners. It was easy to install and the Bluetooth application on my smart tablet allowed me to control the system from the cab without needing to add another box and hoses into the cab. The air cylinder adjustment allowed me to safely and easily change the pressure on the row cleaners to improve consistency of cleaning residue. The ability to change the pressure of the row cleaner by lifting or pushing down greatly improves performance and cannot be duplicated by just changing a pin adjust. Frankly, I would not set up another planter without it.”

Jeff Bridgewater – Bridgewater Farms • Blairstown, Iowa

Martin-Till® Customer Testimonials



Smart Clean™

“With the difference in tillage practices, having on the go control over our row cleaners was a necessity. Using industry-leading technology, the Martin-Till® Smart Clean™ product enabled us to have total control from operators seat to really fine-tune one of the most important tools on our planter without adding more clutter to our tractor cabs.”

1345 Row Cleaner UMO Combo

“Moving into faster planting speeds with newer planter technology, our needs from our row cleaners changed. The Martin-Till® 1345 row cleaner gave us the ability to increase our planter speed while still managing our residue without disrupting the ride of our row units, while still maintaining the superior performance that we have come to expect from Martin Industries.”

“Nitrogen management has become more important than ever in our corn crop. Using the Dual Unit Mounted Nitrogen Applicator, we were able to place our nitrogen instead of just apply it. Couple this product with the superior performance of the 1345 row cleaner and it created a combo that truly is the best in the industry.”

Brandon Hunt – Hunt Farms

Farmer & Tractor Pulling Professional • Hopkinsville, KY



UMO Nitrogen Coulter – Row Cleaner - Smart Clean™

“This is my first year using Martin-Till® products. I was looking for the ability to apply liquid starter fertilizer when planting both corn and cotton, and be able to clean the row ahead of the fertilizer coulter. The UMO fertilizer coulter in combination with the Martin-Till® 1360 row cleaner is the solution I chose. I also chose it because it allows for different depth and placements setting. It allows me to expand to dual placement on both sides of the row in the future, which I am considering doing based on my results this season. I also had excellent results with the Smart Clean™ row cleaner control system. The MartinTill® products are very well designed and durable, and Martin Industries stands behind their product with excellent support and customer service.”

Paul Rogers – Rogers Farms • Avid Conservation Farmer • Wakefield, VA



UMO Nitrogen Coulter

“We have used the UMO Fertilizer coulter from Martin-Till® for 10 years now. It has consistently worked better for us than the OEM nitrogen coulter previously installed. We had experienced plugging and shear bolt issues with our previous openers and since we have installed the Martin-Till® opener, we have experienced much easier use and maintenance over the years. We even have a fair amount of rocks to deal with. I like the ability of the coulter to place the fertilizer below the soil surface, and that it is not surface-dribbling or pressure-injecting the liquid. We have planted about 20,000 acres with them here in Central New York.”

Eric Lyon – Lyon Farms • Lyons, NY



1360 Row Cleaner UMO Combo

We have used Martin row cleaners for over 7 years now and when we set up our new planter we chose Martin row cleaners again. We like the ability to intersect the wheels so that it tills a small area in the furrow strip. They also do a good job of moving stones and residue. We did not have any problems with the first set of row cleaners as they were extremely durable and well made. With the second set of row cleaners we installed the Martin UMO fertilizer disc coulter to put fertilizer 2 inches from the furrow. It did an excellent job of keeping the fertilizer spaced a correct distance from the furrow. Our farm is pleased to run Martin-Till equipment and would recommend it to other farmers.

Robert Donald—Raymond Donald & Sons, LLC—Moravia, NY

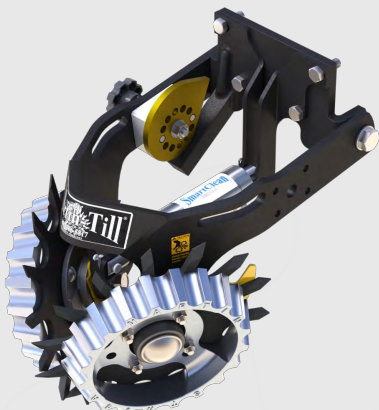

BD1360D

SCCYL2X2=cylinder

SCBD1360=Brackets

Add **Z** for

Razor

Wheel in

place of

Spike

BD1360Z



BD1360D

Example

- **B**= Bundle
- **D**= Deere 7200 and up
- **1360**= 60 deg or
- **1345**= 45 deg
- **D**= Deluxe which includes Cam adjust and Side Treader Wheels

Smart Clean Cylinder and mounting bracket must be ordered separately,

- **SCCYL2X2**= Air cylinder
- **SC-BD1360**= Adding **SC** to beginning of bundle number specifies cylinder mounting brackets

Without Coulter

- **D** = Deere 7200 and up
- **KW** = Kinze 2000,3000,All White and Harvest International Laser Pro 1
- **K4** = Kinze 4000
- **CIH** =Case IH 1200
- **H** = Horsch

Fits OEM No Till Coulter

- **DC** = Deere 7200 and up
- **KC** = Kinze 2000,3000
- **K4C**= Kinze 4000

BK41345Z Basic

K4= Kinze 4000

Z= Razor

1345=45 deg



BDC1360 Basic

C=Coulter





Warranty

Martin Industries, LLC warrants its product to be free from defects in materials and in workmanship for one full year from date of sale to the original user.

- ◆ The warranty is valid if Martin Industries LLC is notified of the defective part within 30 days.
- ◆ Martin Industries, LLC has the option to either repair or replace any parts that were determined to be defective due to material or workmanship.
- ◆ Any improper use, including operation after discovery of defective or worn parts, operation beyond rated capacity, or substitution of parts not approved by Martin Industries, LLC. shall void this warranty.
- ◆ No dealer, employee, or representative is authorized to change this warranty in any way or grant any other warranty unless such change is in writing and signed by an officer of Martin Industries, LLC at its home office.
- ◆ Martin Industries LLC will not replace row units or other manufactures parts that may be damaged during use.



Martin-Till[®]

The most trusted name in no-till[™]

206 Elk Fork Road • Elkton, KY 42220
Phone: 800-366-5817 • Fax: 270-265-9896
www.martintill.com
www.store.martintill.com
sales@martintill.com

V121519



ISO 9001:2015
Certified

